

PRODUCT INFORMATION

DIMENSIONS

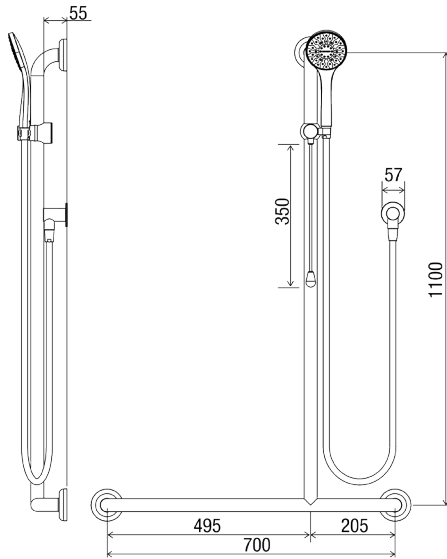

INDICATIVE IMAGE



ACCESSIBLE SHOWER KIT

Product Code - Finish

- IC 01820 CC2 RH/6.5 - Commercial Chrome

Features

- Brushed Stainless 700 mm x 1100 mm grab rail RH (Right Hand)
- 32 mm grab rail fabricated from 304 stainless steel
- 78 mm pre-formed domed Clam® Flange
- Friction Slide handset cradle
- Push-PullMe® shower height adjustment rod
- Hoscare® handpiece with Biomaster antimicrobial additive
- Chrome plated DR brass wall outlet elbow
- PVC 2000 mm Silverflex™ hose with ½" BSP swivel conical end nut
- 57 mm solid brass round flat flange
- Chrome plated finish
- Licenced dual check/non-return valve
- Stainless steel fixings supplied
- Full pattern spray



Compliance

- Meets the requirements of AS 1428.1:2021 Design for access and mobility
- Complies with AS 1428.1:2021 section 12.5.6 (e) allow access and adjustment from a seated position
- Licenced dual check/non-return as per Watermark AS/NZS 2845.1 WMKA 02696
- Watermark AS 3662 WMKT 21147
- 3 Star - 9 L/min as per WELS licence number 0046
- 4 Star - 6.5 L/min as per WELS licence number 0046



Warranty

See Con-Serv warranty policy for full details.

CON-SERV CORPORATION AUSTRALIA PTY. LTD.

17 Glentanna Street, Kedron · Qld. 4031 Australia

Phone: +61 (0)7 3630 5744 · Fax: +61 (0)7 3630 5755 · Email: mail@con-serv.com.au · www.con-serv.com.au